



# HYDROVAR

INCREASED FLEXIBILITY AND CONTROL WITH NEW GENERATION

**xylem**  
Let's Solve Water



HYDROVAR,  
the modern  
variable  
speed pump  
drive is taking  
pumping to a  
new level of  
flexibility and  
efficiency.

- Motor or wall mountable
- More flexibility
- Cost savings
- High level hardware design
- Easy to commission
- Energy savings up to 70%
- Simple mounting "clip & work"
- Multipump capability up to 8 pumps
- Enclosure IP 55

HYDROVAR is not only a simple to use speed control system for direct motor mounting. In fact the HYDROVAR product represents an intelligent control system which accurately adapts the demand and offers plenty of advantages for both the operator and the system.

Unique modular design needs no additional master control and enables virtually any configuration of pumps: up to 8 master drives or a mix of master and slave drives.

This is the long-awaited solution for high-level installations requiring failsafe systems with a superior range of features, while its modularity also provides a cost-effective solution for low-level, reduced feature demands.

# Technical Data

HYDROVAR		Power supply		Output to motor	
Type	Rated output	Voltage limits 48-62 Hz	Recommended line protection	Max. voltage output	Rated current output
HV	[kW]	[V]	[A]	[V]	[A]
2.015	1,5	1~220-240 -10%+15%	20	3~3U <sub>in</sub>	7
2.022	2,2		25		10
4.022	2,2	3~380-460 ± 15%	13	3~3U <sub>in</sub>	5,7
4.030	3		13		7,3
4.040	4		16		9
4.055	5,5	3~380-460 ± 15%	20	3~3U <sub>in</sub>	13,5
4.075	7,5		25		17
4.110	11		32		23
4.150	15	3~380-460 ± 15%	40	3~3U <sub>in</sub>	30
4.185	18,5		50		37
4.220	22		63		43



# Dimensions

1,5 - 4 kW

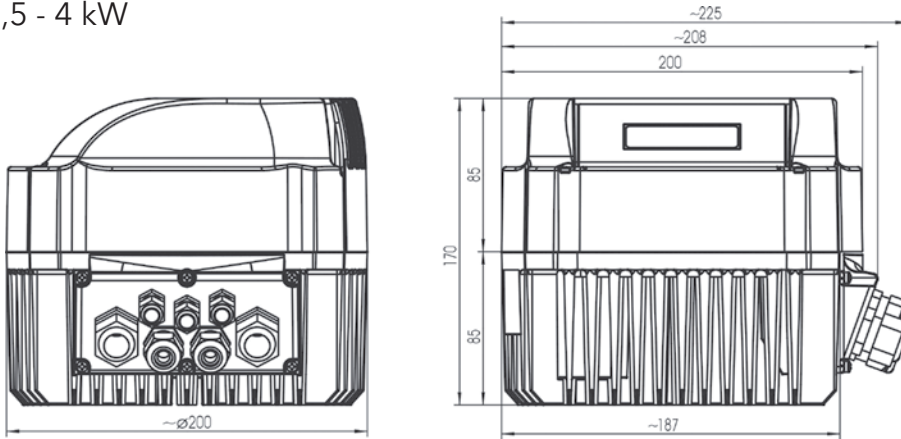

5,5 - 11 kW

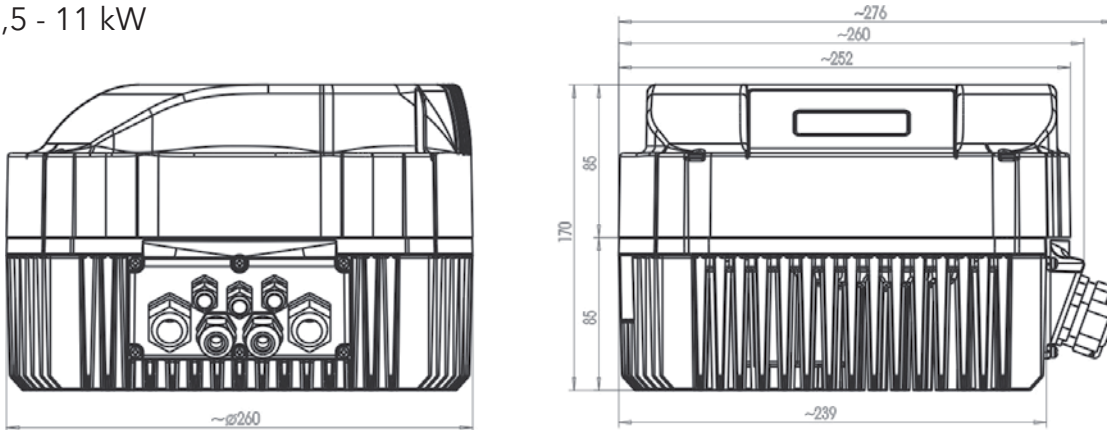

15 - 22 kW

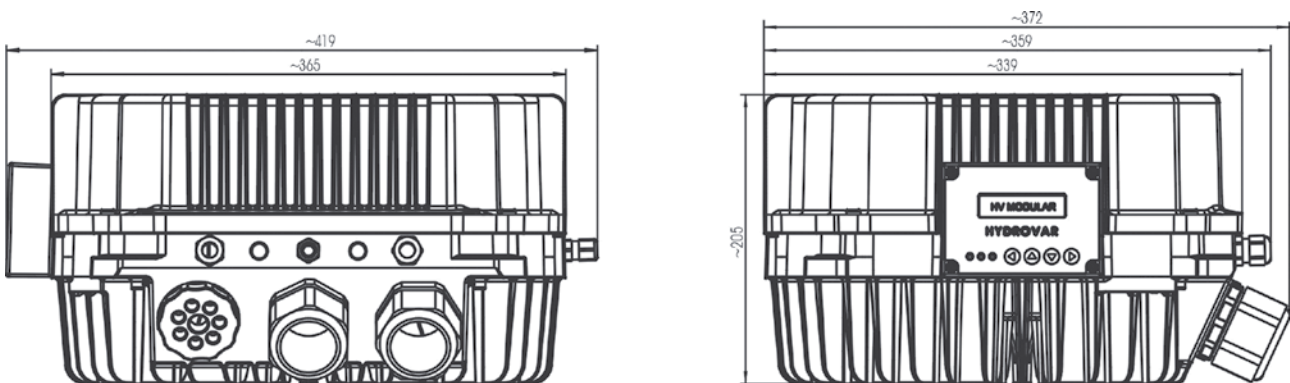

# Advantages

The new HYDROVAR concept allows optimum flexibility and ensures cost savings not only during operation but also in purchasing and commissioning

Easy operation and programming due to the improved menu navigation and the backlight display - even in difficult accessible installations

Error Log with date and time stamp and included diagnostic menu to view temperature, current and quality of power supply facilitates diagnostics and failure analysis

Easy to integrate into building services management systems with MODBUS interface included as standard

Integrated function to protect pump, motor and the overall system

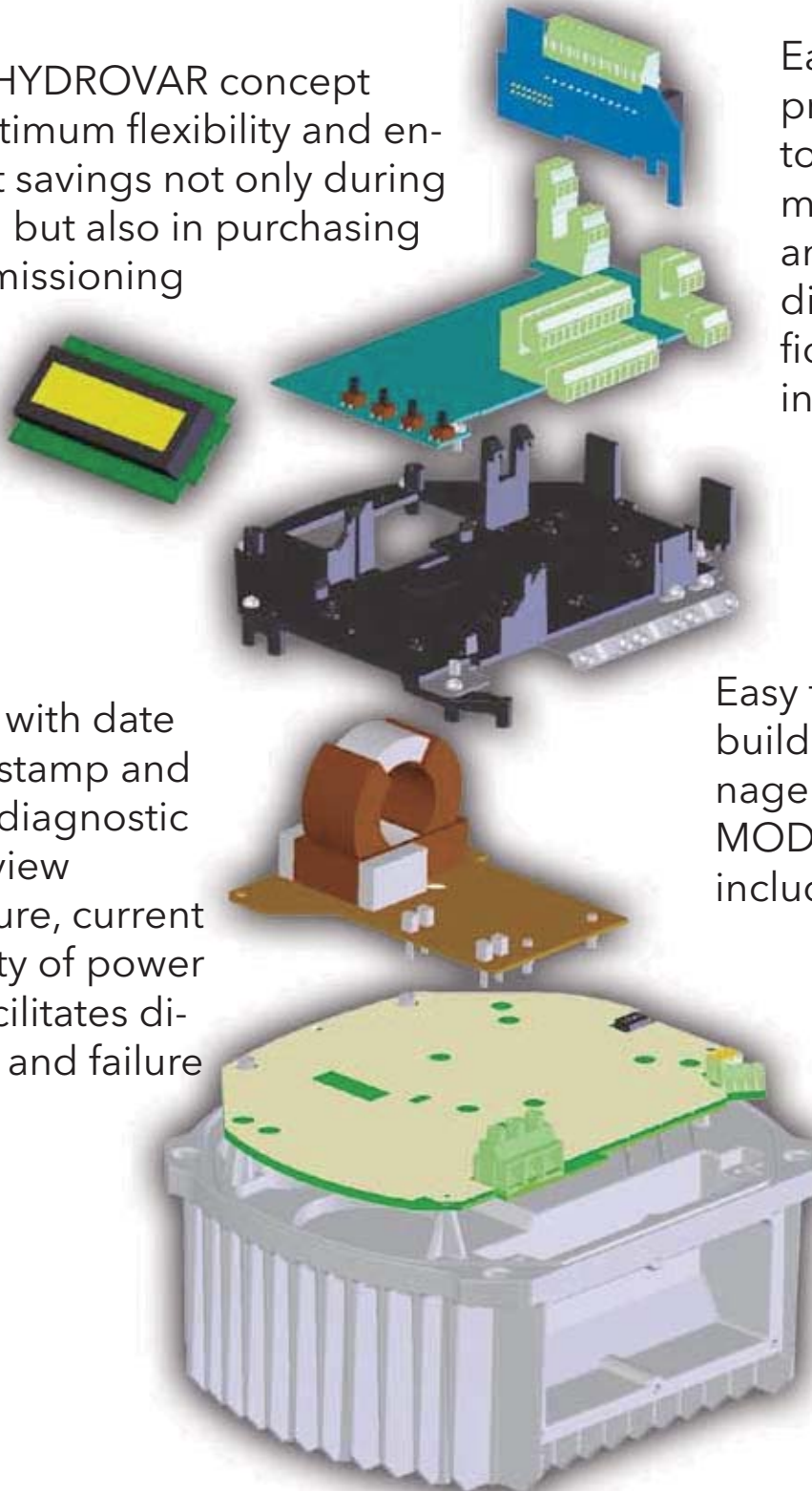

# Advantages

Easy assembly of multi pump systems up to 8 pumps without any external control units or other superior control systems

Greater redundancy and additional application possibilities like zone regulation with 2 connected actual value sensors

Integrated dry-run protection and shut-off the system in case of pipe burst

Extended manual control mode with either external as well as internal set points of different speed levels

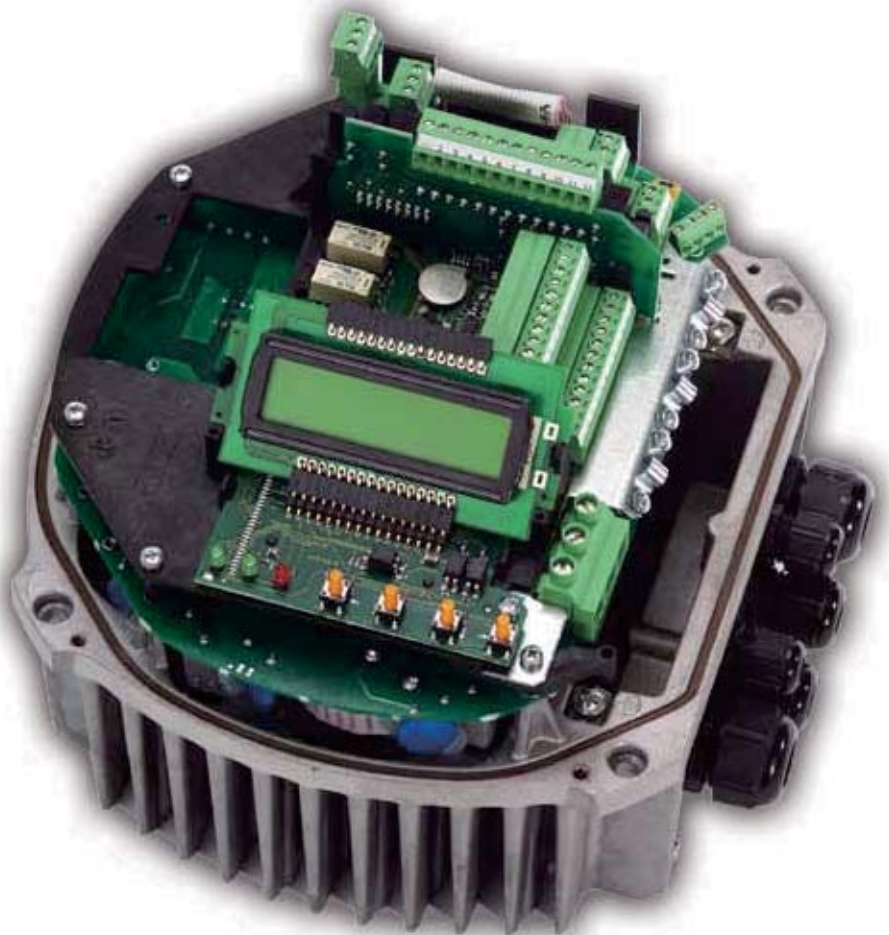

# RETROFITTING

---

is possible on all existing standard asynchronous motors, which are suitable for VFD operation.

---

Automatic adjustment of the pump performance to varying demands.

---

Constant system pressure in water supply and booster stations. Possibility of control along the system curve for circulation pumps for the HVAC market.

---

No external panels, contactors and motor protection devices are required.

---

All hydraulic control functions are included in the HYDROVAR. Therefore no additional external controllers are required.

---

Optimised cooling of the HYDROVAR, depending on the power and the speed of the pump, is guaranteed by the motor fan.

---

Longer maintenance intervals because of less stress to the pump and the motor.

---

The brilliant mounting method of the HYDROVAR unit allows a very simple, fast and inexpensive retrofitting on existing pumps.





# Retrofit



# Clip & Work

Especially in the operation at partial loads of a centrifugal pump there will be significant potential of energy savings!  
„TÜV-approved“



Example:  
Circulation pump with nominal power in partial load operation.

Capacity in %	Power consumption as per curve		Saving in kW	Saving per 1/3 year (2.920 hours)
	Pump at constant speed	Pump at variable speed		
25 %	5,8 kW	1,8 kW	4,0 kW	11.680 kWh
50 %	7,6 kW	3,2 kW	4,4 kW	12.848 kWh
75 %	9,2 kW	5,7 kW	3,5 kW	10.220 kWh
Energy savings within 1 year (8.760 hours)				34.748 kWh



Compared with the installation costs for the HYDROVAR units there will be a payback time of less than one year (depending of the energy costs).

# Product Overview - Hardware configurations

## Single Pump Operation

- Using one Basic Inverter for soft start/stop function



- Using one Single Inverter for speed controlled function



## Multi Pump Operation (Cascade Controller - Relay)

- Using one Master Inverter (incl. optional relay card) to control up to 5 full speed slave pumps

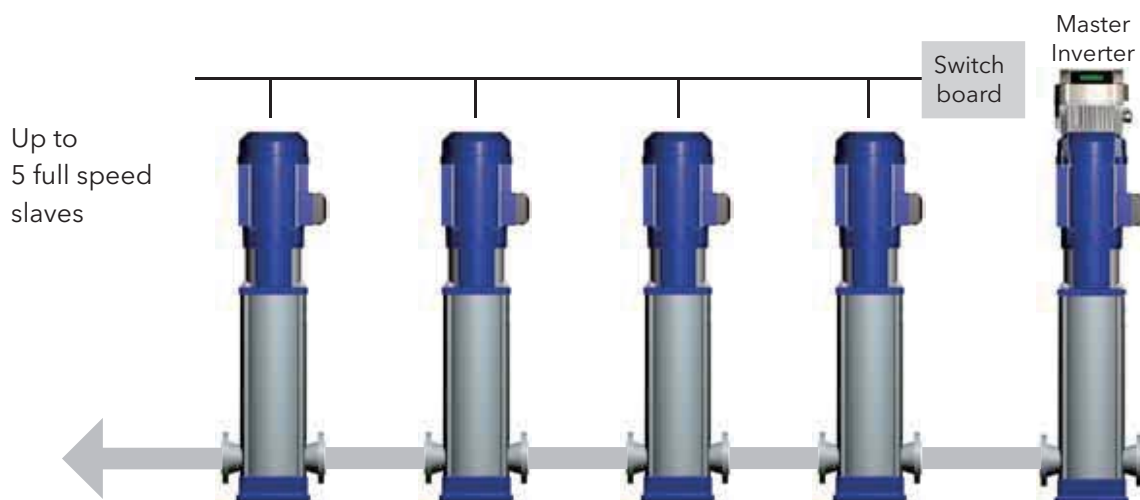

## Multi Pump Operation (Cascade Controller - Serial or Synchronous)

- Using several Master Inverters and Basic Inverters in combination (up to 8 pumps can be combined)

Mixed installation of  
master and slave  
HYDROVAR

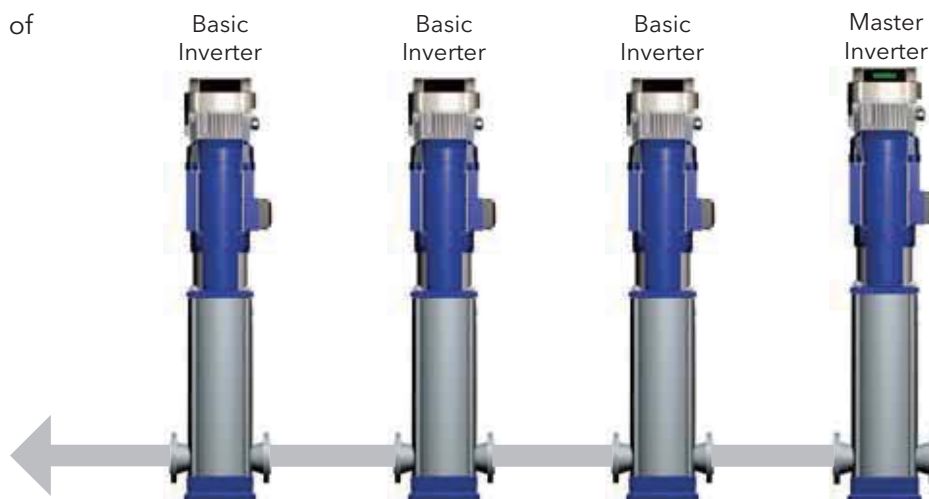

Up to 8 Master  
Inverters

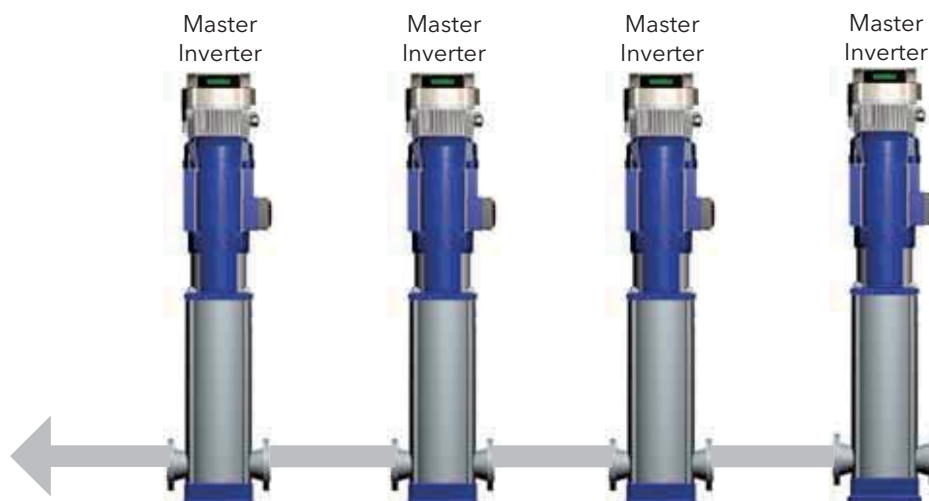

# Xylem |'zīləm|

- 1) The tissue in plants that brings water upward from the roots;
- 2) a leading global water technology company.

We're 12,000 people unified in a common purpose: creating innovative solutions to meet our world's water needs. Developing new technologies that will improve the way water is used, conserved, and re-used in the future is central to our work. We move, treat, analyze, and return water to the environment, and we help people use water efficiently, in their homes, buildings, factories and farms. In more than 150 countries, we have strong, long-standing relationships with customers who know us for our powerful combination of leading product brands and applications expertise, backed by a legacy of innovation.

**For more information on how Xylem can help you, go to [xylem.com](http://xylem.com).**



Xylem Water Solutions Austria GmbH  
A-2000 Stockerau  
Ernst Vogel-Straße 2  
Tel +43-2266-604  
Fax +43-2266-65 311  
[info.austria@xylem.com](mailto:info.austria@xylem.com)  
[www.xylemaustria.com](http://www.xylemaustria.com)